



L1 Simulation Upgrade

December 6th, 2004
BaBar Collaboration Meeting
SLAC

Eric Torrence
University of Oregon



Phase 0 (Now)

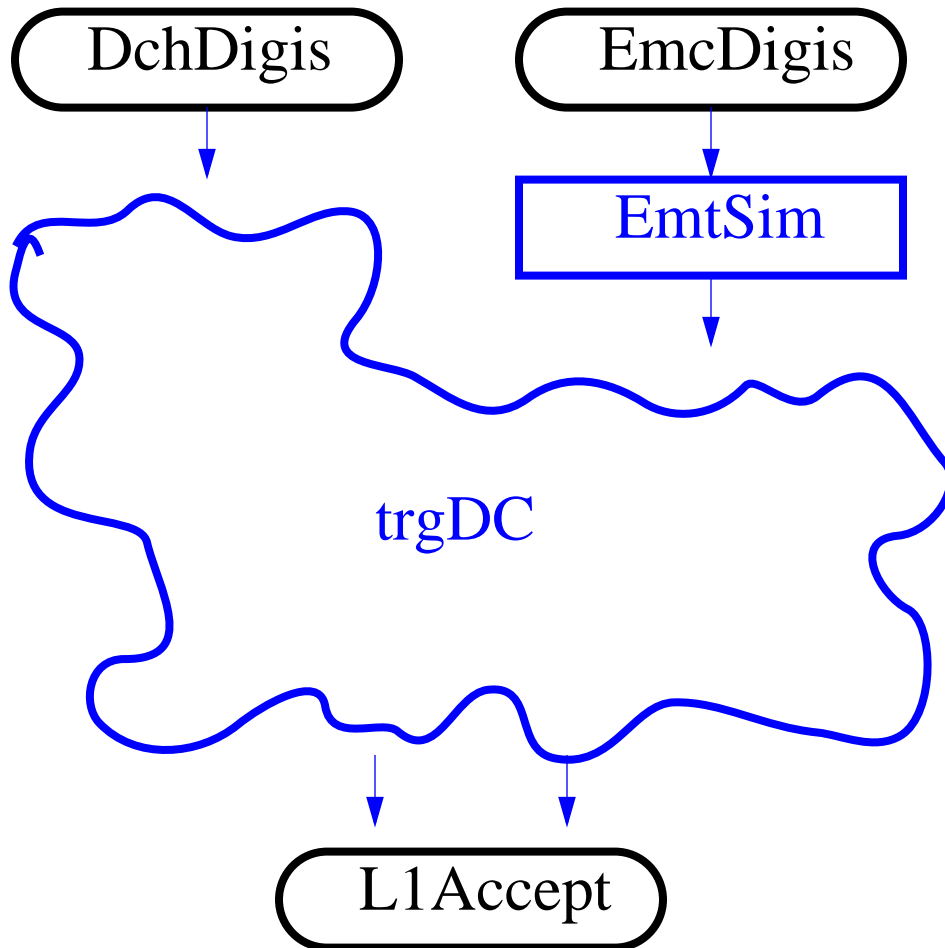

This IS the current SP6 (14.4.X)

Base simulation code unchanged,
but interface elements are updated (**Digis, TsfLUT**)

Remaining changes are inside “black blob”



Phase I

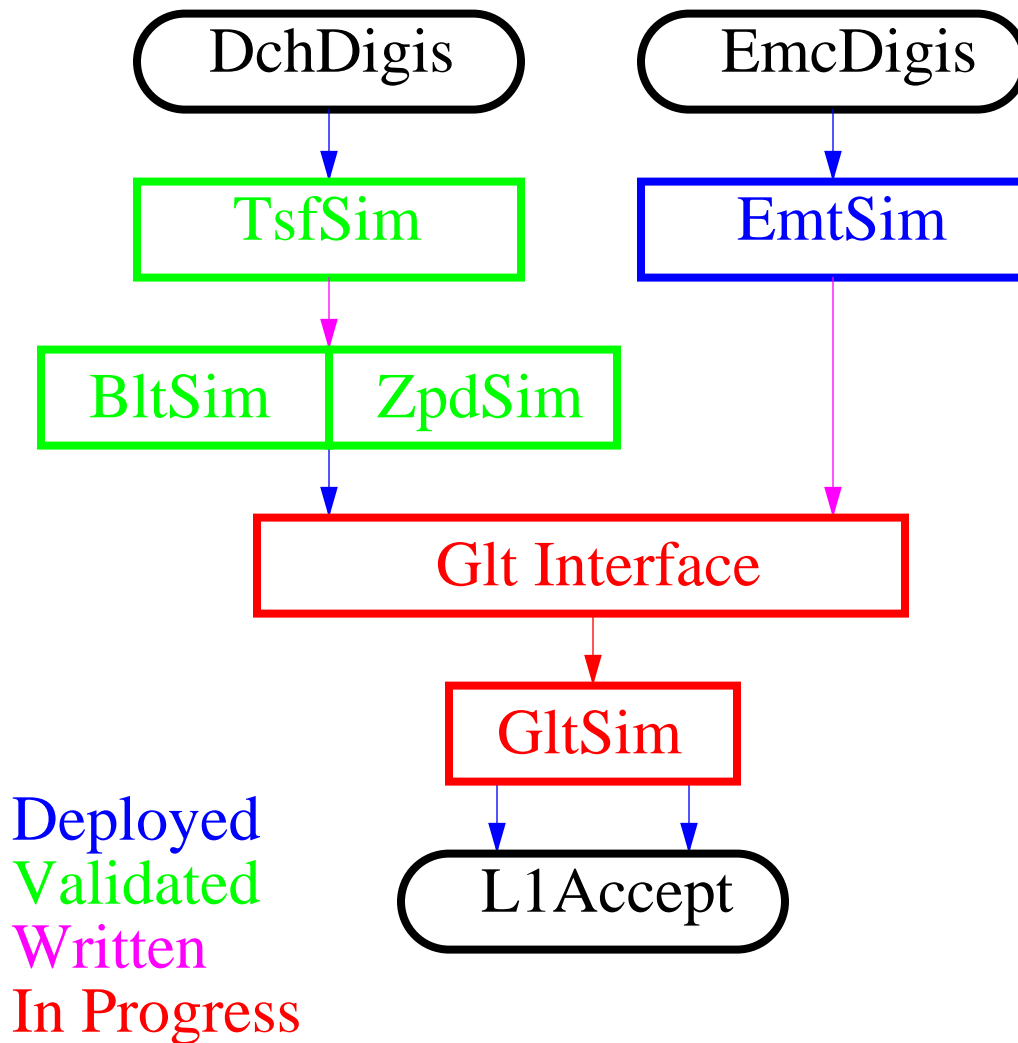

Immediate simulation goal

Needed to simulate Run5 data (SP7)

GLT single biggest code concern



Phase II

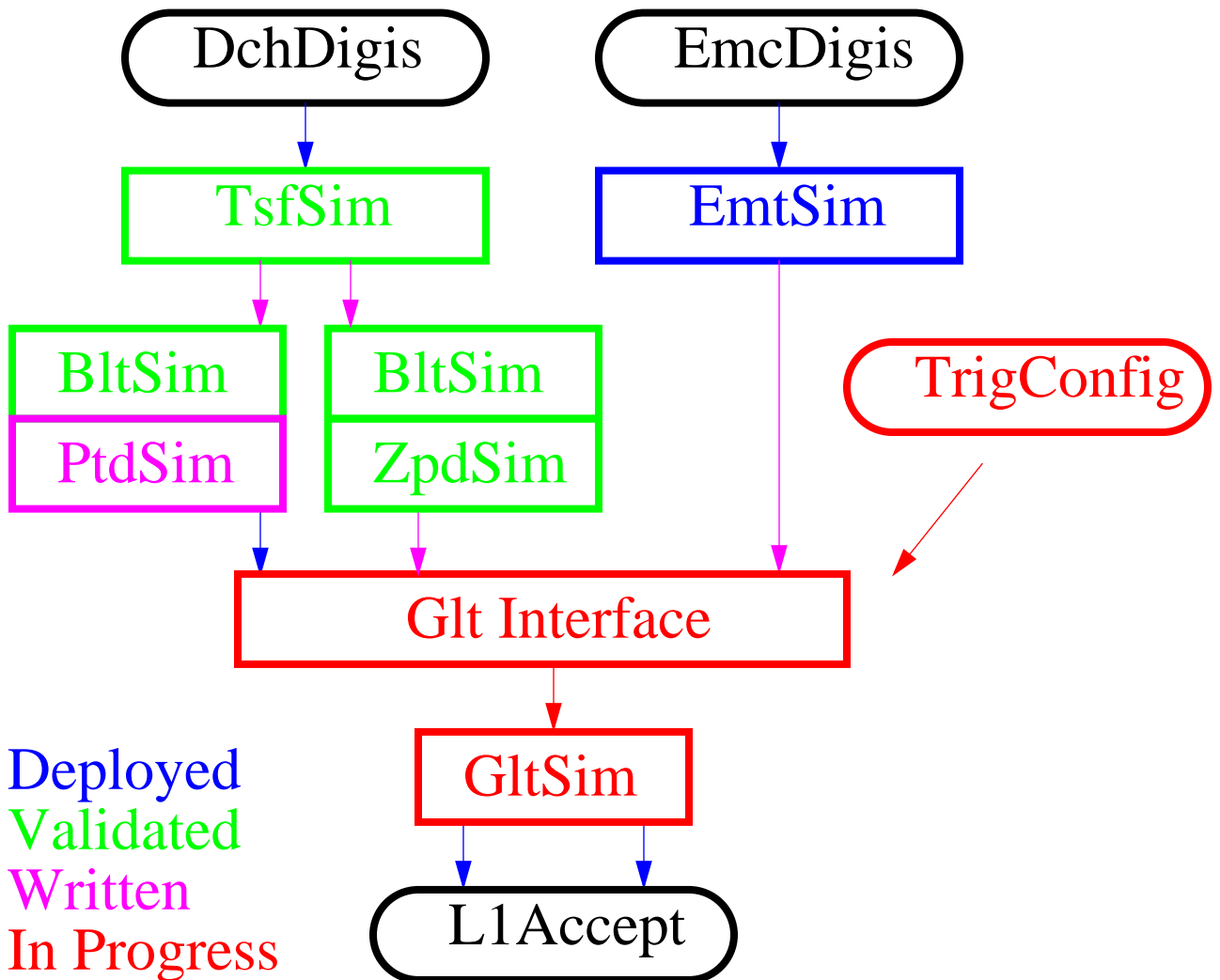

Full L1Sim upgrade (the final solution)
Needed for SP8 (Spring '05)

Old PTD code will be validation challenge



configDB Issues



TSF

- LUT loading modified (Rainer)
- L1DctConfigLoader replaces L1Dct56bitTsfLutLoader - 5/6 bit as required
- New 6bit LUT? (probably longer term)

ZPD

- Change in philosophy
Previous: Basic params + full memory map
Now: Basic params only, generate full map
- Simulation changes minor
- More serious issue for online
- Still needs to be installed in configDB?

BLT

- BLT mask structure understood
- Object needs to be written and installed

Jamie has been working hard
on configDB issues...



Simulation Config



Config Interface

```
class L1DctEnv {  
    L1DctGeom*           getL1DctGeom();  
    L1DTsfLutArray*     getL1DTsfLut();  
    L1DZpdLut*          getL1DZpdLut();  
    L1DBltMask*         getL1DBltMask();  
    ...  
}
```

Proxies stored in configDict, although
user never needs to know that

Interface remains even if underlying
details change

(L1DctGeom is actually hard-coded)

Need to modify simulation code to use
BLT mask and latency values

More on that in a moment...



Config Loading



L3 needs TSF LUT, but nothing else

Non-Sim Version

```
L1TOepEnvSequence (AppUserBuild* forWhom) {  
    BdbConfigInitSequence( forWhom );  
    forWhom->add( new L1DctBuildEnv() );  
    forWhom->add( new L1EmtBuildEnv() );  
  
    // Load TSF LUT  
    forWhom->add( new L1DctConfigLoader() );  
}
```

Sim Version

```
L1TOepSimEnvSequence (AppUserBuild* forWhom) {  
    forWhom->add( new L1DctBuildEnv() );  
    forWhom->add( new L1EmtBuildEnv() );  
  
    // Load TSF, ZPD, BLT, ...  
    forWhom->add( new L1DctConfigLoader() );  
    forWhom->add( new L1DctOtherConfigLoader() );  
}
```

Separate module per board, or...?

Better home for this Sequence?

Currently called directly from

Moose/AppUserBuild



Latencies

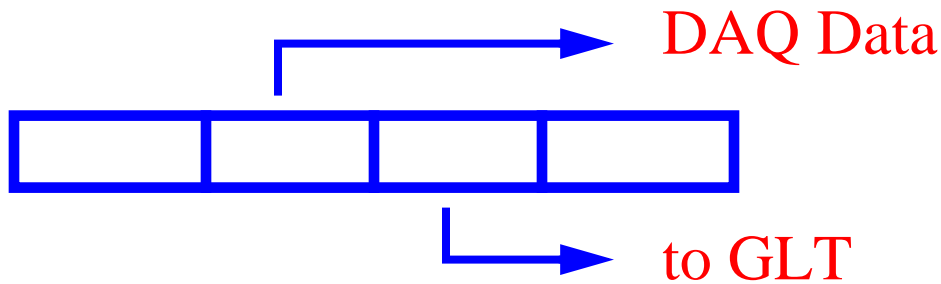

No explicit simulation of hardware latencies

Input parameters to simulation

- Hardware processing time (sim-only)
Different for GLT and DAQ
Different for various DAQ objects
- DAQ delay (configDB)

DAQ: config delay + sim parameters
Must line up properly in L1A window

GLT: config delay (is there one?) + sim
Must line up properly at GLT input

Simulation latency numbers are conditions data
Probably will be hard-wired for now



Latency Concerns



Latency Units

- DAQ delays are fundamentally **integers**
- Different clocks used in different boards

Significant chance to mix **clk4/clk8/clk16...**

Make simLatency L1SimTickClock object?

Latency Precision

- Adjustable parameter in simulation
- Want to match data distributions

How much precision is necessary?

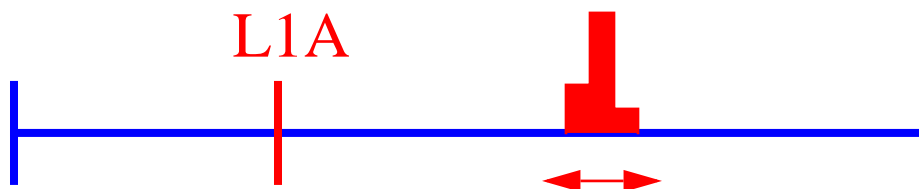

Make all sim latency numbers clk8 or clk16?



TSF - BLT Data Path



- DW Segments converted to SC hit patterns
- BLT reducer performed within TSF
- Ambiguity in documentation

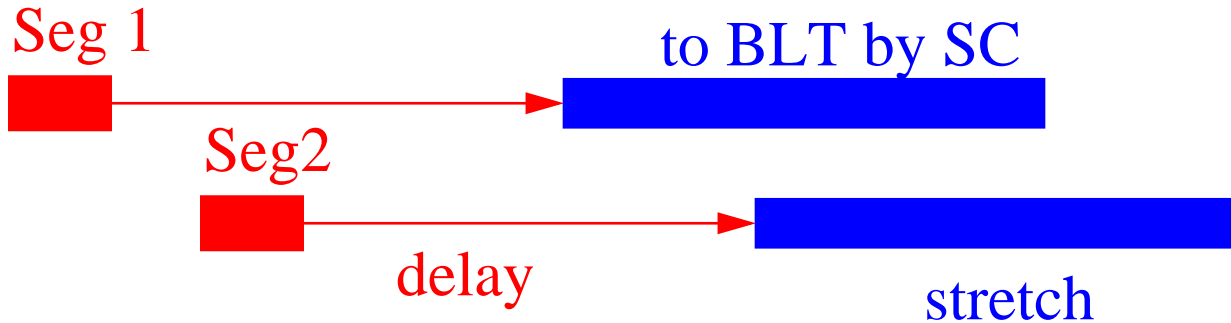

What if segments are in same SC, and second has higher weight?

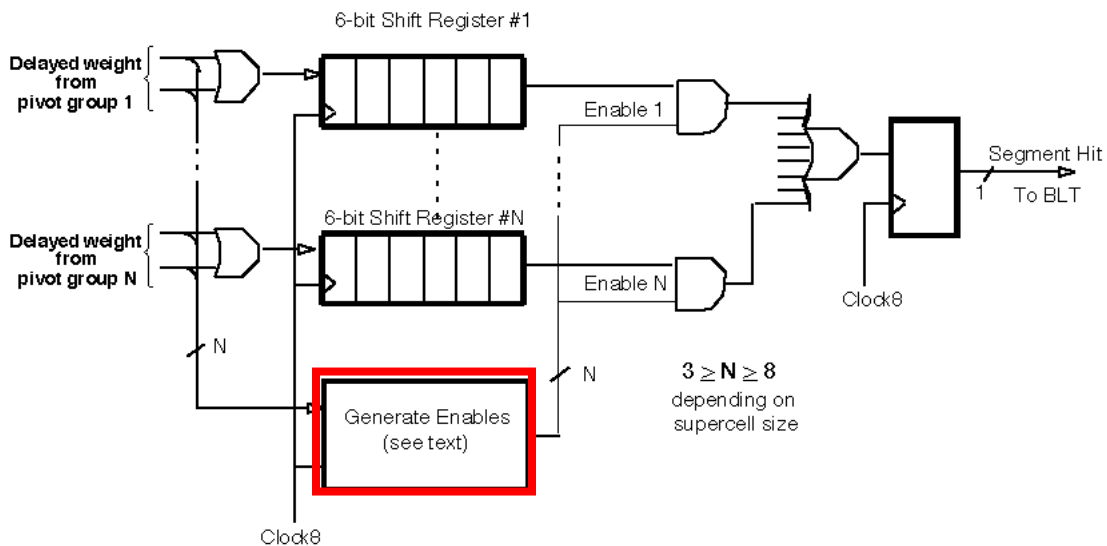

Figure 12. Details of the BLT Data Reducer block.



Digi Making Code



After L1Accept, must create DAQ simulation
and apply L1A window

Forgot to ever write ZPD modules...

- L1DZpdInputDigi - Needed translation from cell number into cell hit map. Done
- L1DZpdTrackDigi - cellLocation and cellPhi are not currently being simulated. Skip for now?
- L1DZpdDecisionDigi - most important. Done
- L1DZpdStatusDigi - simulate for completeness

Need to track down TSF/ZPD window numbers
Will these ever change?



GLT Inputs



At Match and Combine

All are in timebuffers, one object per tick

- **BLT**

```
TB<L1DBltPhiMap> _bltA, _bltB;
```

- **ZPD (new stretcher added)**

```
TB<L1DZpdDecisionSimDigi> _zpd;
```

- **EMT**

```
TB<L1EmtGltData> _emt;
```

- **PTD - still to be finalized**

Timebuffer tools make it easy/accurate
to convert clk4 <-> clk8

Need to apply latencies at this point



Simulation Output



2004/12/06 12.24

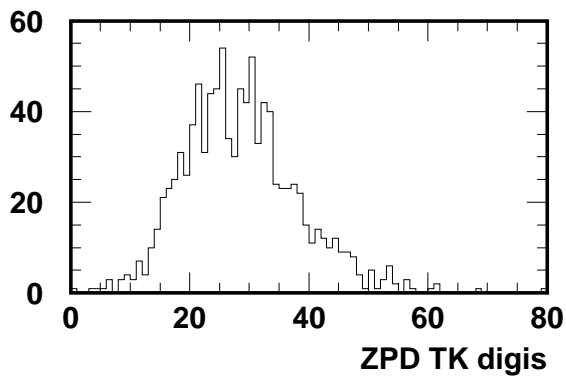
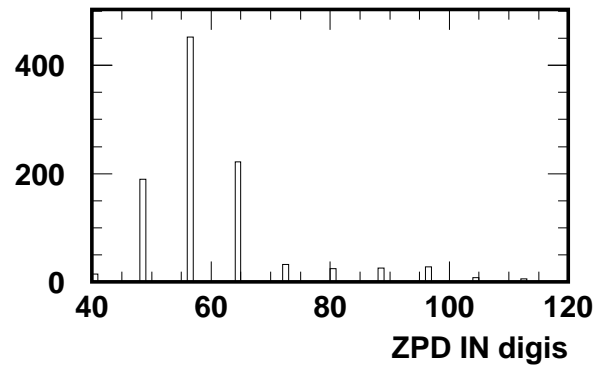
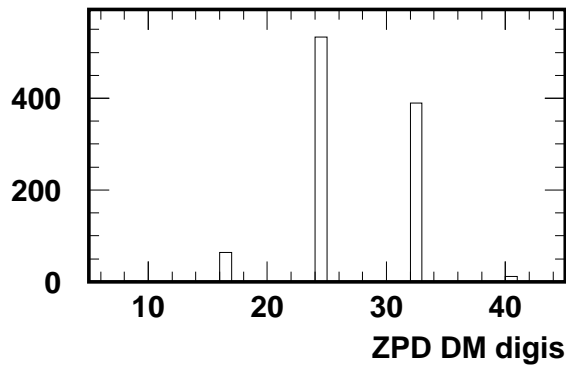
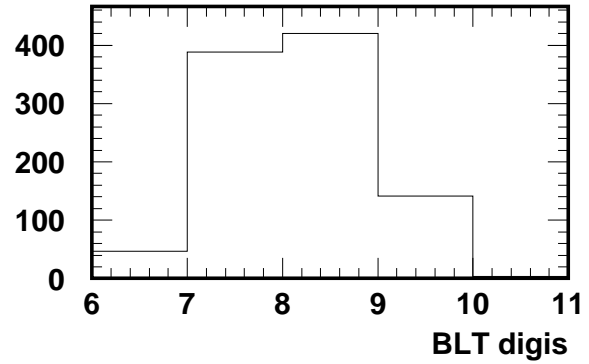
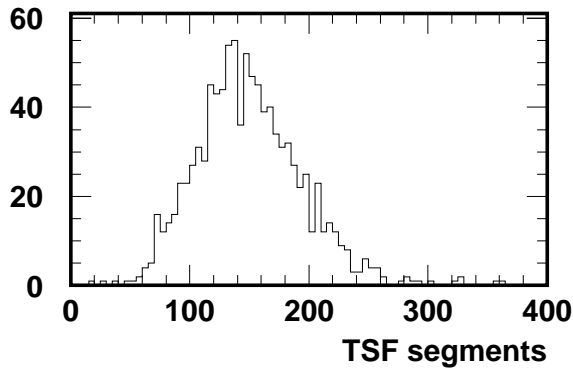

Not obviously wrong, need some data ntuples...



Simulation Output II



2004/12/06 12.34

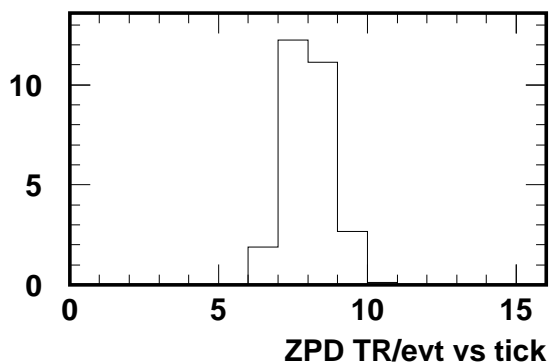
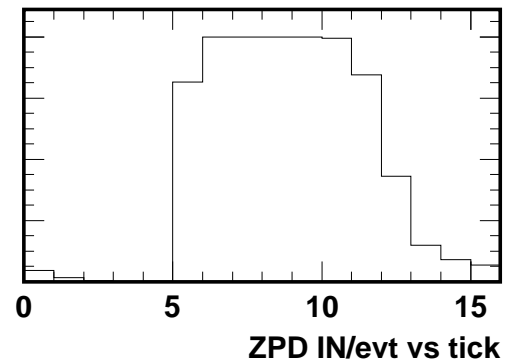
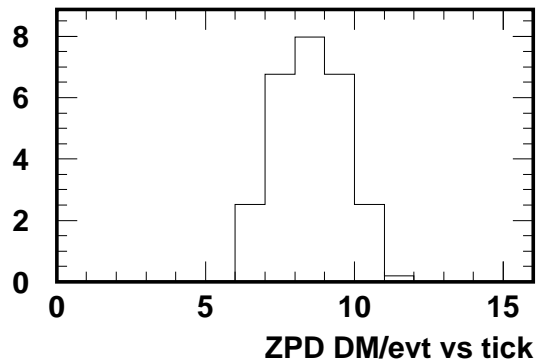
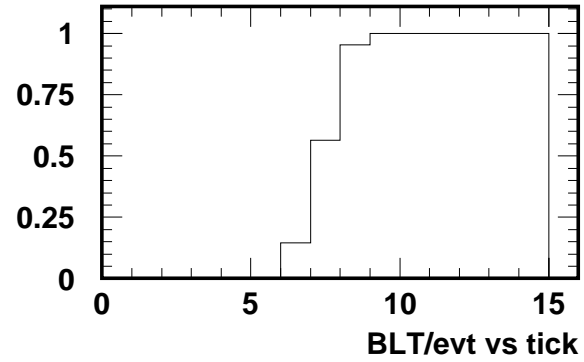
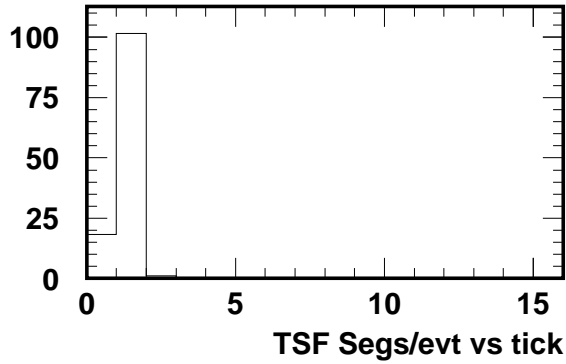

Not digested or checked
Starting point for latency tuning



Remaining Work



Now Critical - SP7

- GLT simulation code
- Finish configuration objects
- Install current objects into configDB
- TSF -> BLT data path validation
- System validation (MooseApp)
- Latency simulation and tuning
- Documentation...

Near Future - SP8

- Finish PTD simulation
- trigConfig modifications
- tcl-based old/new switching